



***FulBore***  
*Resin Models*

## '70 HT BE-UTE TRIBUTE



# KIT ASSEMBLY INSTRUCTIONS

[www.fulboremodels.com](http://www.fulboremodels.com)

GMH Produced a number of show cars in the early 70's. One was the 1970 HT Ute, named the Be-Ute. It was finished in "Torrid Violet" duco and featured many of the GTS Monaro components. The Be-Ute was built in the GMH Styling Department.

There's not a great deal of information about this great project, and I suspect it's a very distant fading memory for those involved, so I hope this model kit helps preserve some of the great work GMH did back in the day.

**Thanks for your purchase, and I truly hope you have  
fun building your Be-Ute.**

## BEFORE YOU START.

If you've bought this model, it's likely that you have, at some time in your life, put together a plastic model kit. This is a great start! Ideally, you are an experienced model builder for this model. If not, please read the instructions carefully, and do some research before you start the assembly. I've tried to make the fitment of all the parts as good as possible, but in the end, this is a home made kit, not a Tamiya!! Please be patient and take your time.

I've left some of the smaller delicate components on their printing supports for you to enjoy removing! I'd love to remove all of them for you and save you the time, but the supports help me make sure the tiny pieces in the kit make it to you safely intact. I've tried to model all the components with as much detail as possible. Consequently, some sections of the individual pieces are smaller than the supports supporting them. Refer to the pictures in the instructions which are the actual print files, which will hopefully help you tell what's support, and what isn't.

**New to RESIN Models?** – Read on..... Most model kits over the years have been made from Styrene, using an injection moulding process.... Cutting to the chase, this is a 3D Printed RESIN kit, and the plastic used to make this kit is different to model kits in the past – even different to Cast Resin. Resin is a “thermo-setting” plastic, meaning it hardens with heat, so all the old tricks of heating up styrene model kits to modify them go out the window. Normal modelling glue won't work with resin, and resin can also be a bit more brittle than styrene, so please be careful when handling pieces.

**IMPORTANT: Each part of this model will need sanding and preparing to remove layer lines, supports, and other remnants from the 3D print process.  
Test fit all parts before committing them to glue.**

**Keep parts out of direct sun until painted, as UV will deteriorate the resin (it is UV that is used in the print process to cure the resin, so more UV will make parts more brittle)**

**Clear parts in this kit appear cloudy out of the box, but once a clear coat paint is applied, they become fully transparent.**

If you have any questions, or are not happy with any aspect of the model, please contact us first at [www.fulboremodels.com](http://www.fulboremodels.com), and we'll do our best to help you.

# RECOMMENDED MINIMUM TOOLS & MATERIALS

- Tweezers, bent & straight.



- Hobby Knife & “Sprue” Cutters – the finer & sharper the better, for removing parts from supports. Small scissors come in handy too.

- Small modelling files, and sanding sponges / sticks for preparing and fitting parts. 400-1500 wet and dry paper works too.



- Rubber bands & a variety of small clamps (clothes pegs work too) for clamping pieces together after gluing.

- Pin vice drill.



- Plastic putty.



- Thick (gel) and thin CA (Cyanoacrylate - super glue) or 5-minute epoxy. (normal model glue will not work with resin). Foam Safe CA Glue will be required for clear parts. Thick gel is handy for applying small amounts of glue



- Degreaser or wax and grease remover.
- Modelling masking tape, and masking gel.



- Primer suitable for resin - similar to modelling glue, styrene and plastic primers won't stick to resin. Outlaw Paints is Australian owned and the primer is excellent for resin models, with superior filling capabilities.

- 



- Decal softener & hardener

## NICE STUFF TO HAVE FOR A BETTER JOB (OPTIONAL)



- Molotow Liquid Chrome Pump Markers

- Polishing compound and a rotary tool (Dremel or similar) with die grinding bits, and polishing pads.



- A gloss clear coat system



# SAFETY FIRST

When working with the materials required for the construction of this kit including adhesives, primers, paints, resin parts etc, always work in a well-ventilated area,

3D printing resin is considered toxic and when printing these models, the recommended precautions are taken to avoid contact with the resin. Whilst the resin is considered safe to humans when cured, It is recommended that the necessary precautions are taken to prevent the inhalation of dust when sanding, cutting or filing resin. Wearing a dust mask and working in a well-ventilated area is recommended as a minimum precaution. It is also recommended to wear safety glasses when removing parts from their supports, to prevent pieces of resin ending up in your eyes.

Please also follow all precautions on any products used to build your model, and be careful when using sharp tools.



# SYMBOLS USED



Glue



Do not glue



Make a choice



Paint Colour



Cut



Apply water slide decal

# PAINT COLOUR GUIDE

You may need to experiment to get exactly the colour you want to paint your HG, but I've listed some paints below that I think are close. Outlaw Paints has a selection of Factory HK-T-G Colours and I've listed some of these that the HG Ute was available in.

FOR BETTER RESULTS, MINIMISE PAINT ON SURFACES THAT NEED TO BE GLUED

## EXTERIOR COLOURS

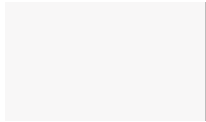

Kashmir White  
Outlaw Paints - Kashmir White



Warrigal Black  
Outlaw Paints Jet Black Paint



Torrid Violet  
Outlaw Paints - Morpheous



Sudan Beige  
Outlaw Paints - Beige

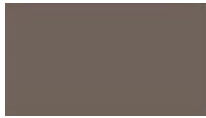

Cinnamon Brown  
LifeColor LC37 Acrylic Paint - Matt  
Burnt Umber



Cambridge Blue  
Outlaw Paints - Cambridge Blue



Rally Red  
Zero Paints Red Arrows - Signal  
Red Gloss



Warwick Yellow  
Outlaw Paints - Warwick Yellow



Tunisian Turquoise  
Outlaw Paints - Tunisian Turquoise



Indy Orange  
LifeColor #LC04 Acrylic Paint -  
Matt Dark Yellow

## INTERIOR COLOURS



BLONDE IVORY available with  
Tennessee Turquoise, Inca Gold or Burgundy Maroon.



TEAL BLUE available with  
Ermine White, Macleods Blue or Paragon Blue.

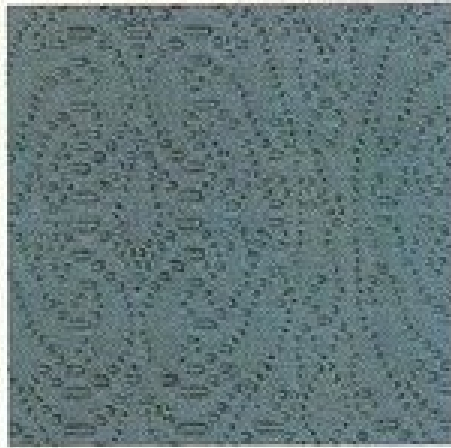

BLACK available with  
all the exterior colours shown above.



Blonde Ivory  
Outlaw Paints -  
Hyper ellow



Teal Blue  
Outlaw Paints -  
Tunisian Turquoise



Black  
Outlaw  
Paints -  
Nero Ade  
Leather

## OTHER



Under body, Interiors etc  
Mr Hobby – Semi Gloss Black



NOTE, some parts that need to be black are printed in black. You can just apply a clear instead of paint in some cases.



Engine  
Outlaw Paints – Rocket red



Metal parts  
Outlaw Paints – White Aluminium  
or  
Alclad - 101 Aluminium Lacquer



Chrome  
Molotow Liquid Chrome Pump  
Markers  
or  
Outlaw Paints – Chrome  
or  
Alclad II – 107 Chrome



Exhaust manifold, and pipe  
Outlaw Paints – Dark Iron  
Mr Hobby Burnt Iron – H76

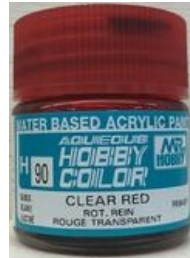

Brake lights  
Mr Hobby Clear Red – H90



Turn signal lights  
Mr Hobby Clear Orange – H92



Headlight Glass, mirrors etc.  
Mr Hobby Clear – H30



# ASSEMBLY

## 1. CHASSIS

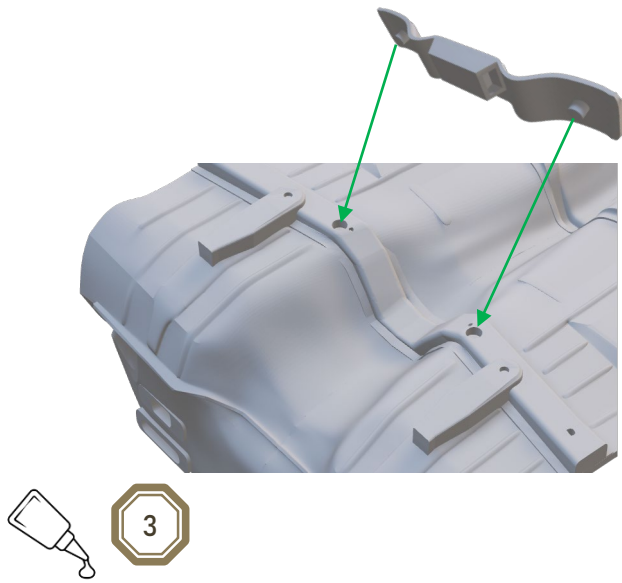

## 2.

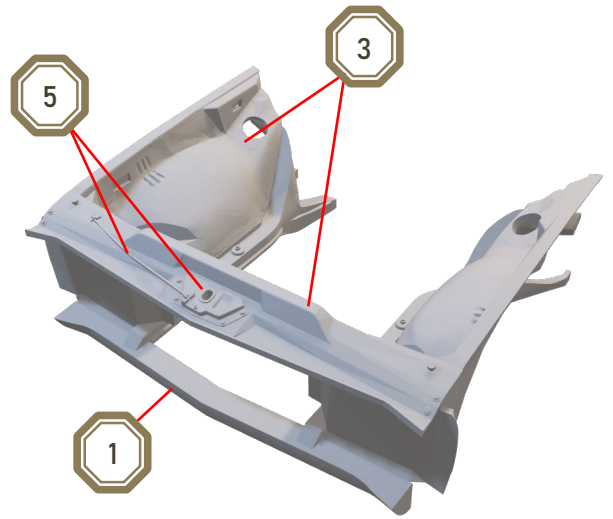

## 3.

Temporarily insert the floor pan into the body and glue the front inner guards and chassis to the floor pan to ensure correct alignment with the body. Once the glue is dry, remove from the body and continue.

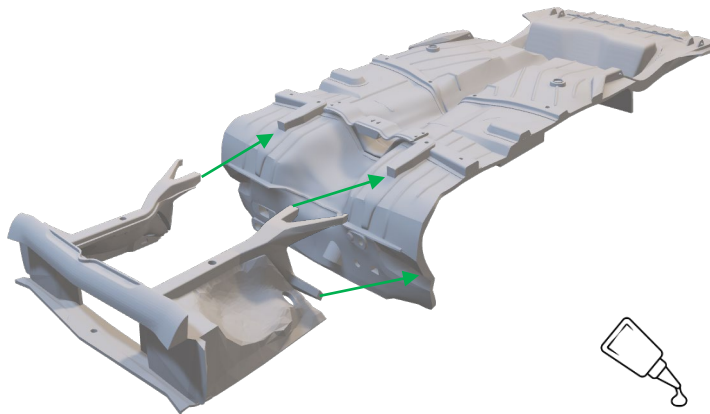

## 4. ENGINE

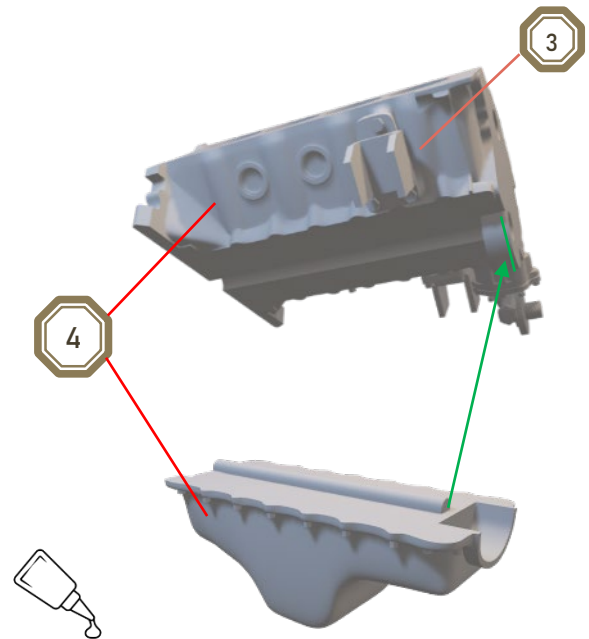

## 5.

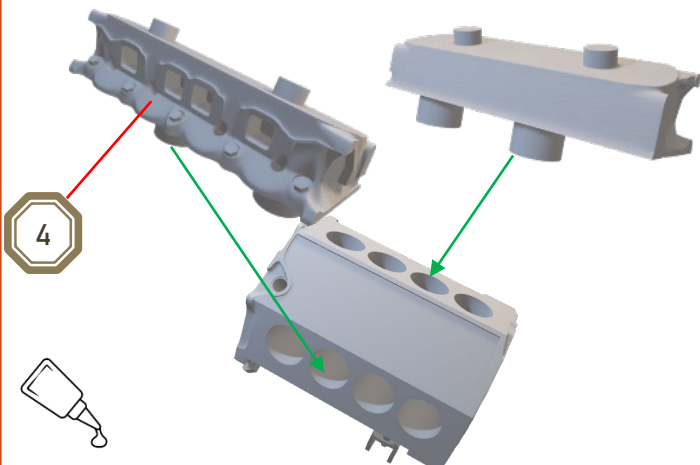

## 6.

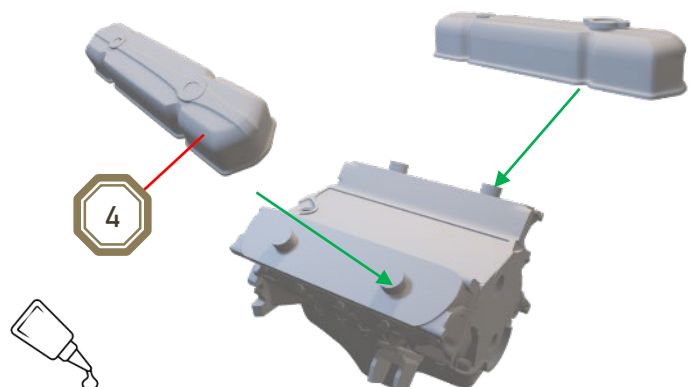

7.

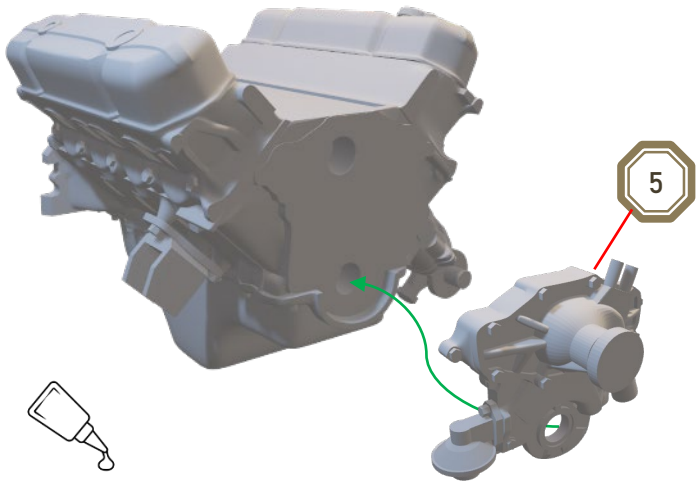

8.

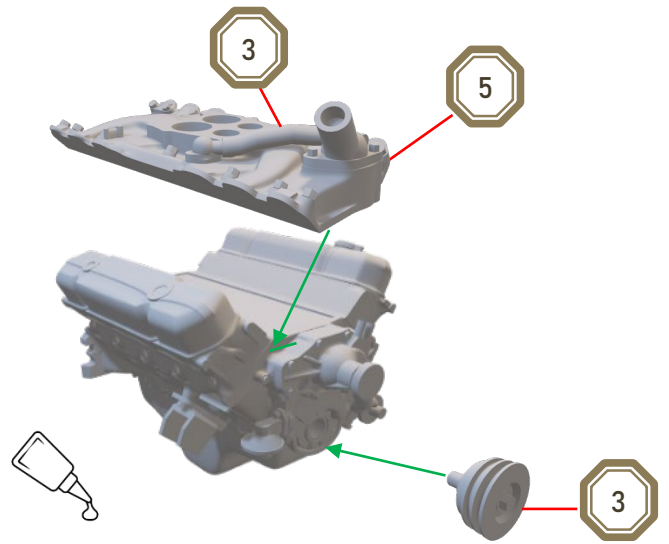

9.

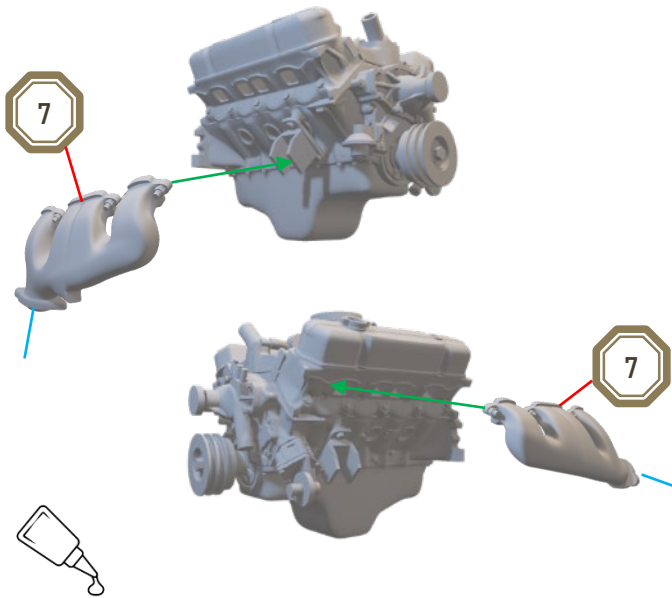

10.



Install optional plug leads before attaching distributor

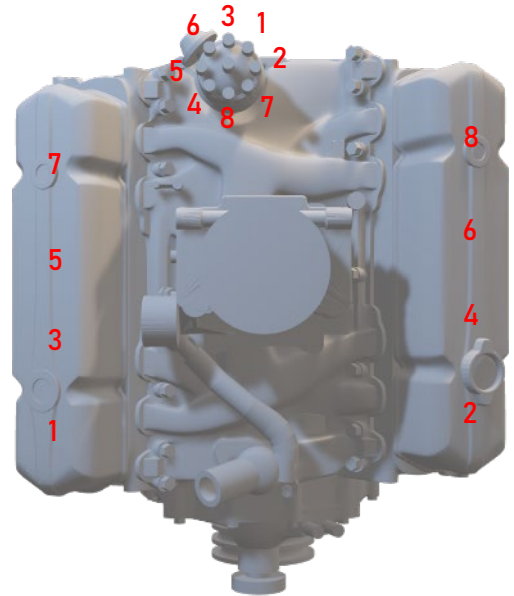

11.

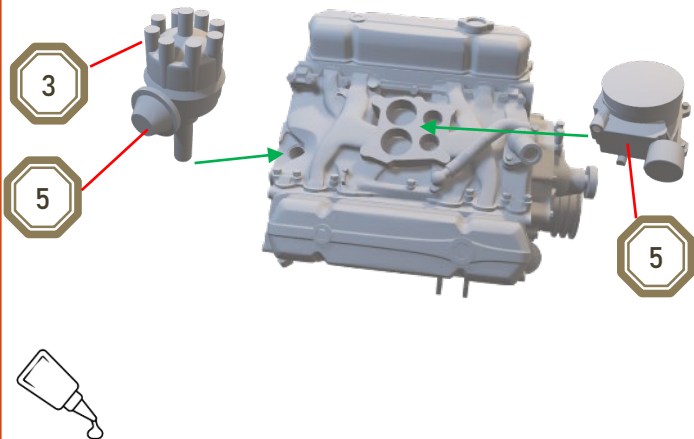

12.

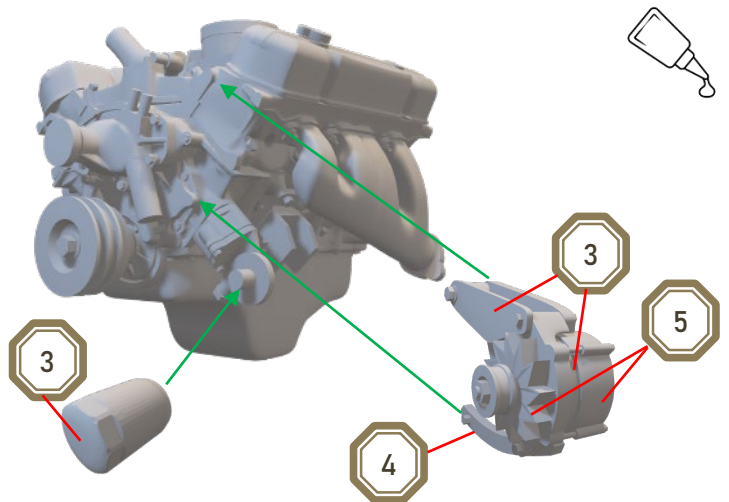

13.

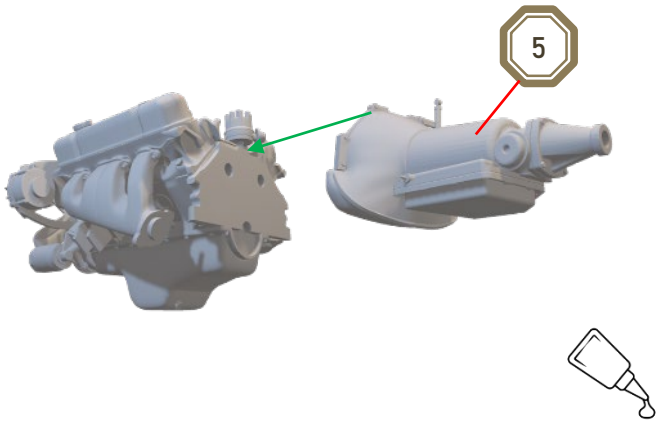

14.

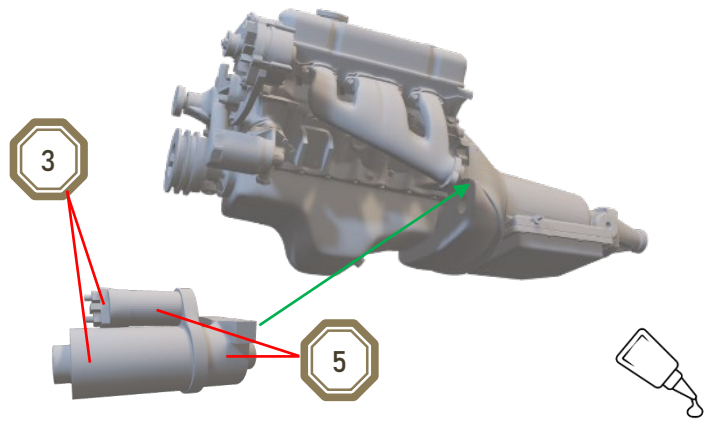

15.

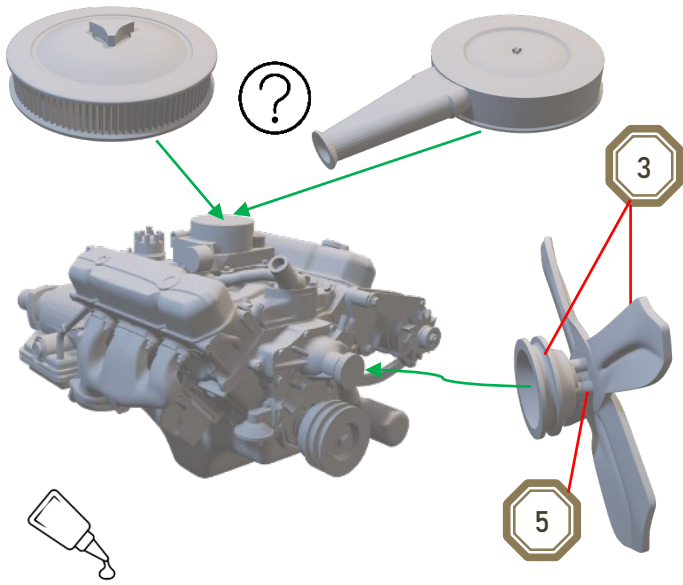

16.

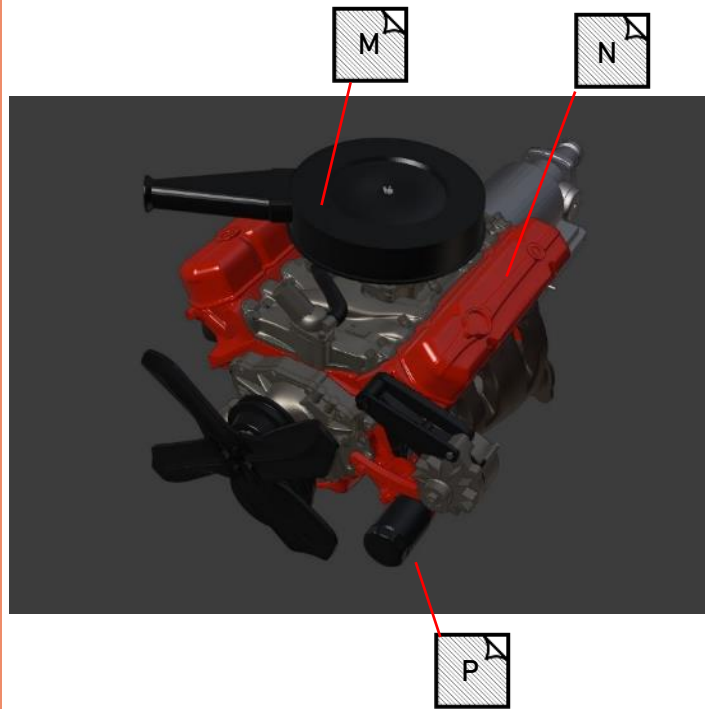

## 17. ENGINE BAY

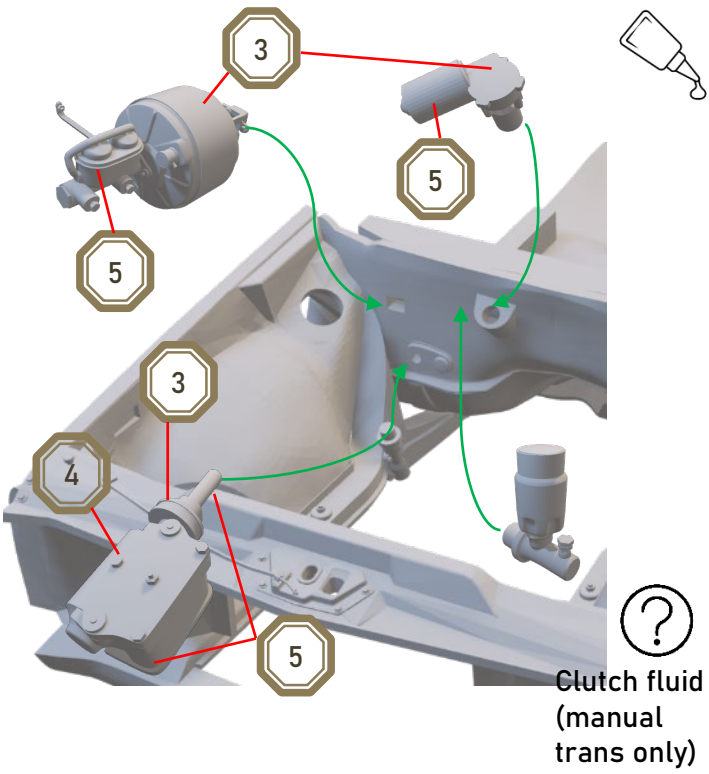

## 18.

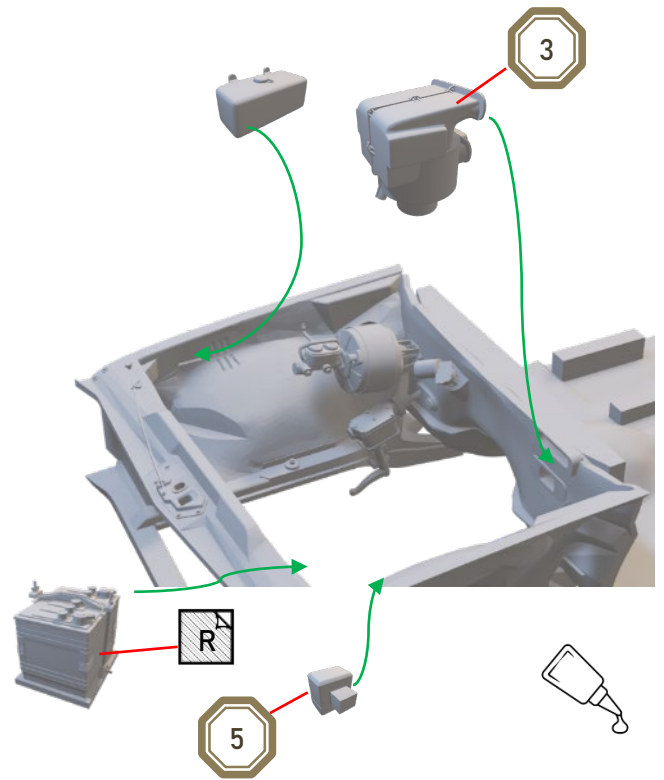

## 19. WHEELS

x4

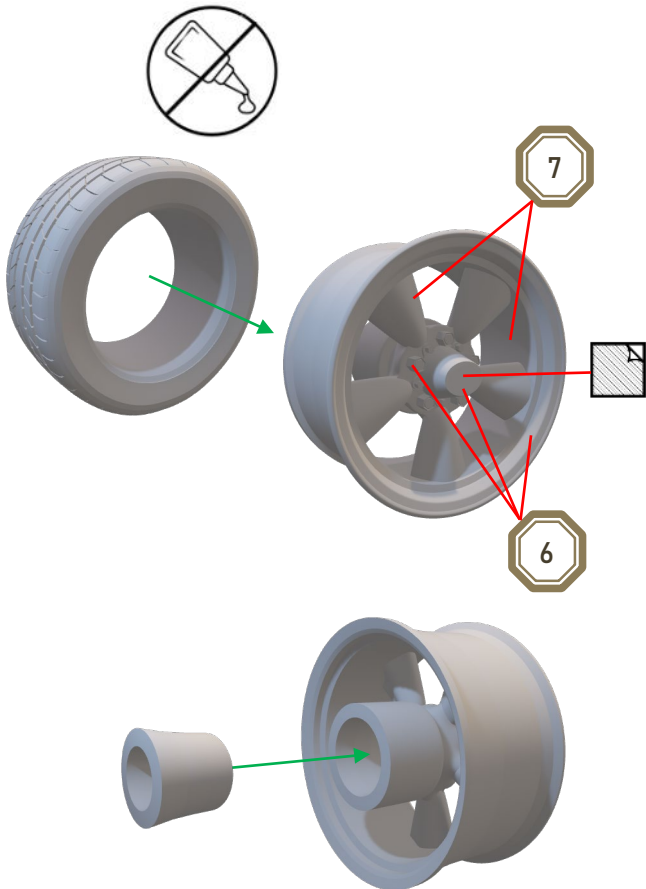

Set your wheels aside. These will be needed soon to adjust the ride height of your HG.

20.

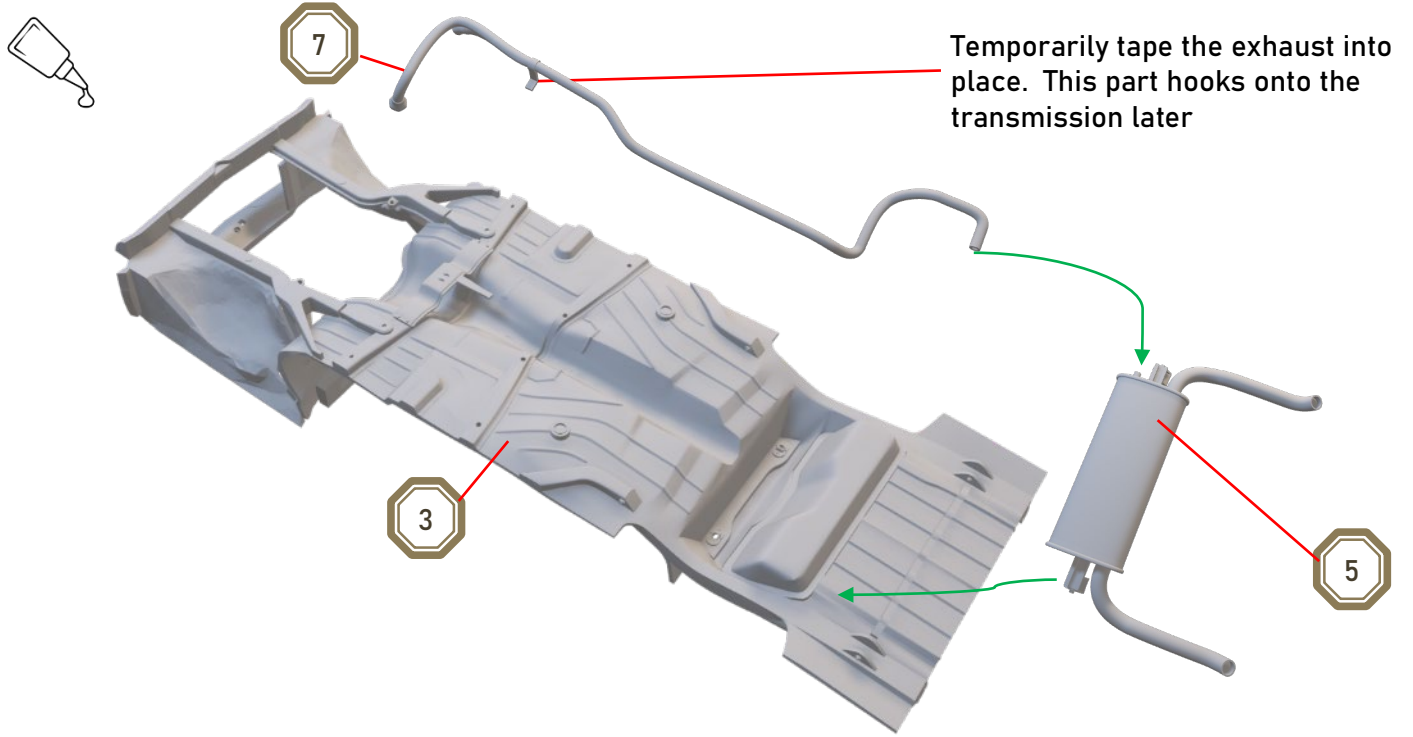

## 21. SUSPENSION

x2 (L&R)

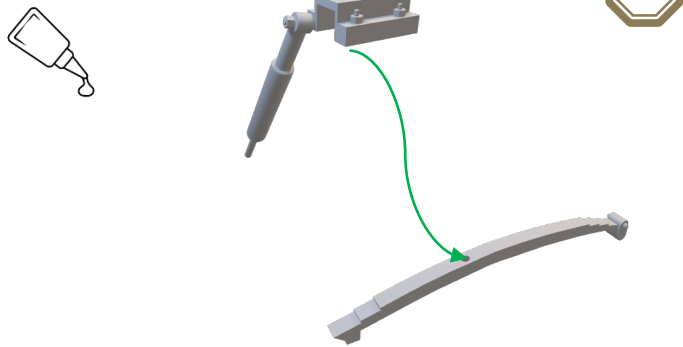

22.

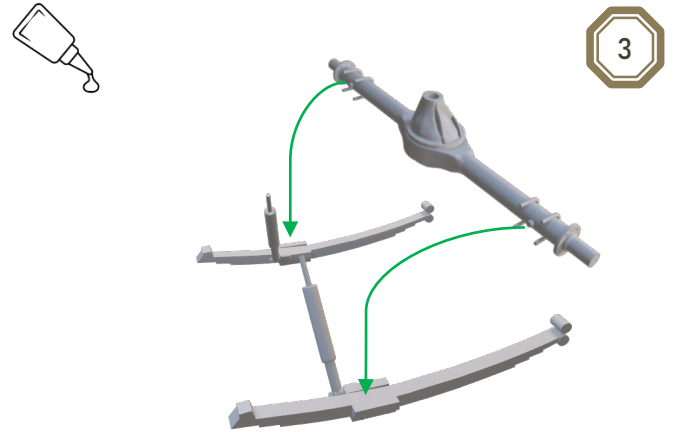

23.

If you want a lower stance than standard, put your floor pan and chassis back into the body temporarily. Fit your wheels onto the axle. Cut the end of the springs before gluing them into place.

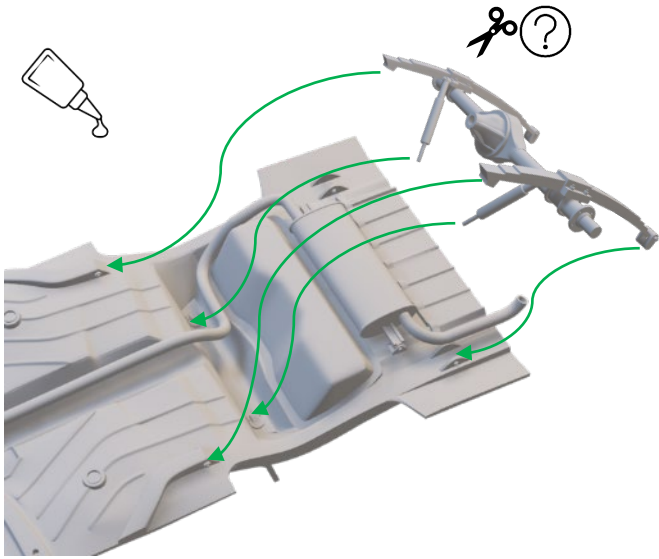

24.

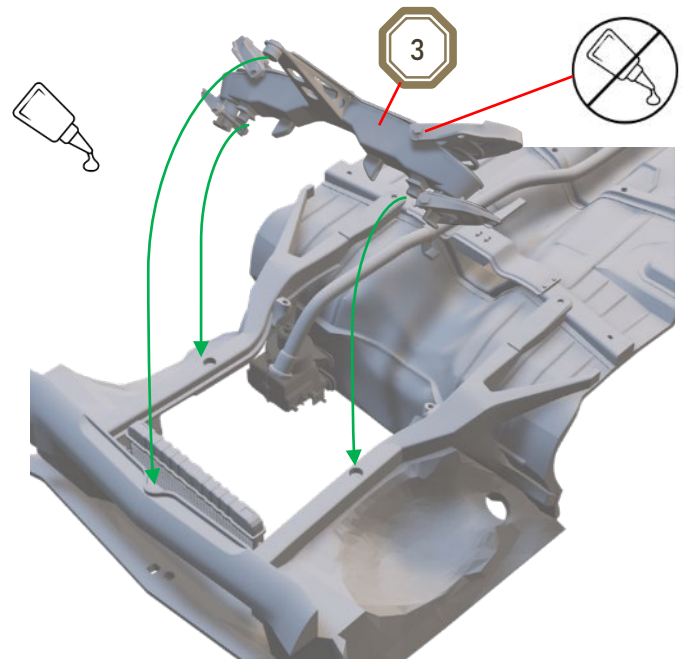

25.

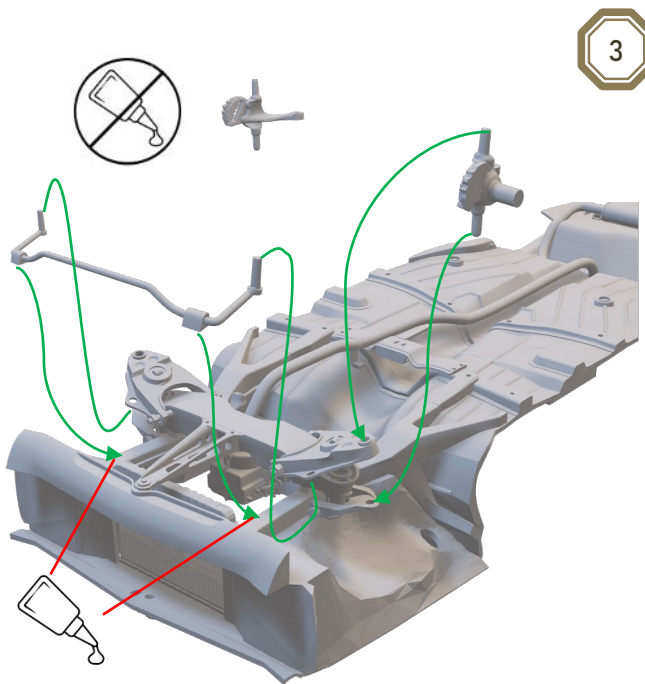

26.

Once the spindles are in, fit the wheels and adjust the front ride height. Once you're happy with the height, glue the suspension control arms (wishbones) into place. This step is really tricky, so please grab a stiff drink & take your time 😊

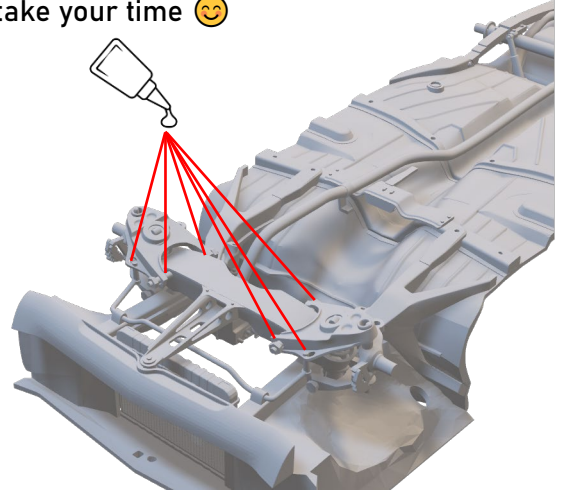

27.

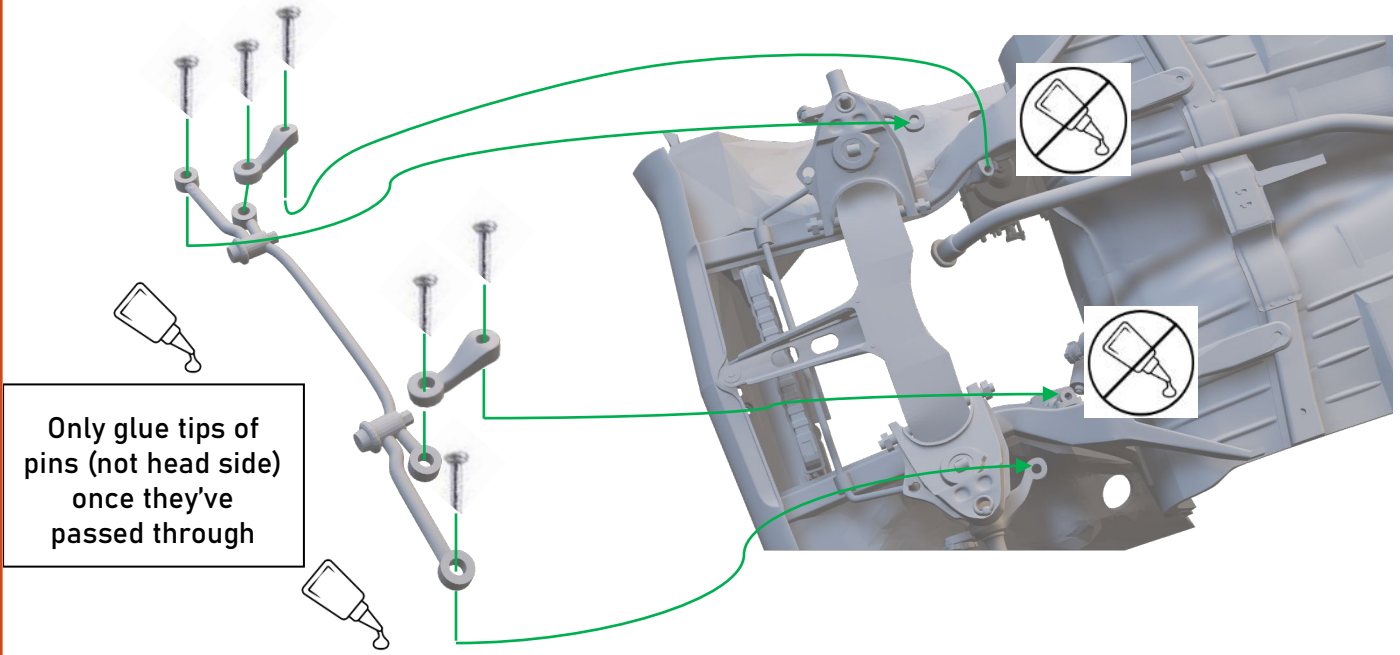

28.

Cut clutch pedal off for auto transmission

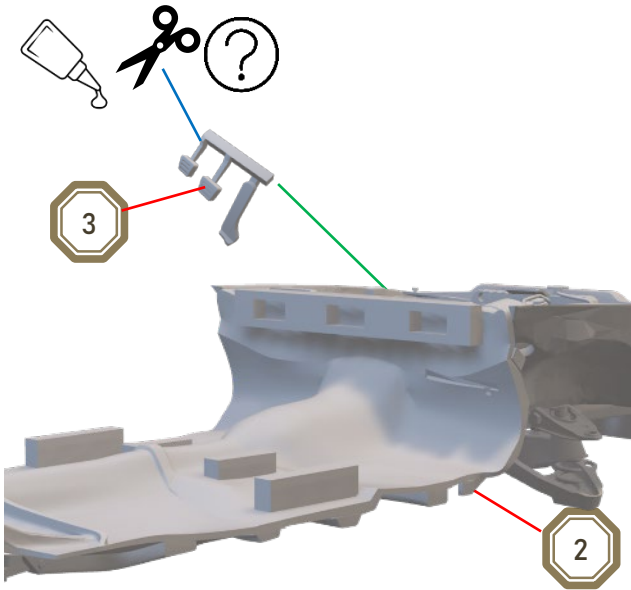

29.

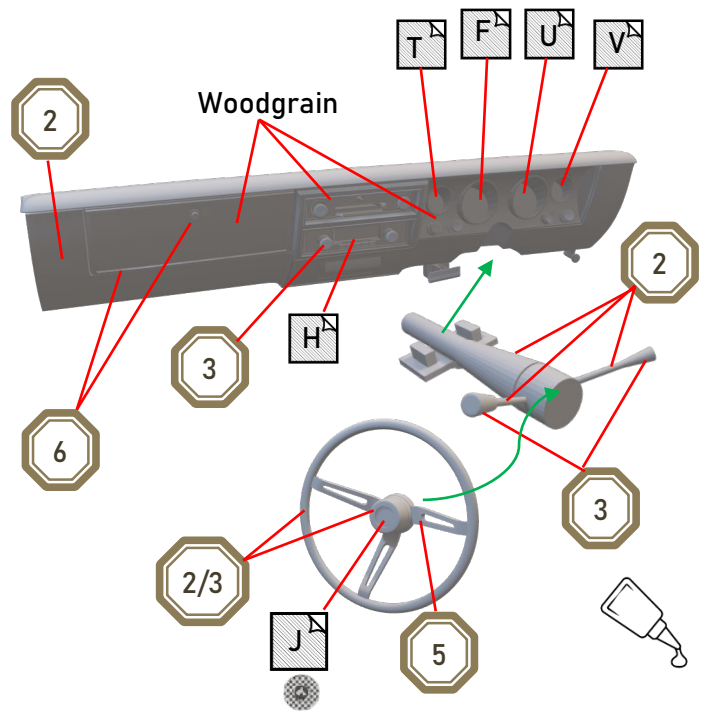

30.

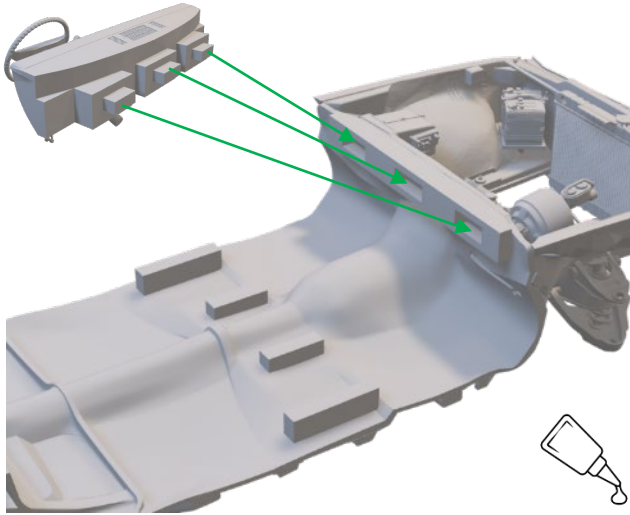

31.

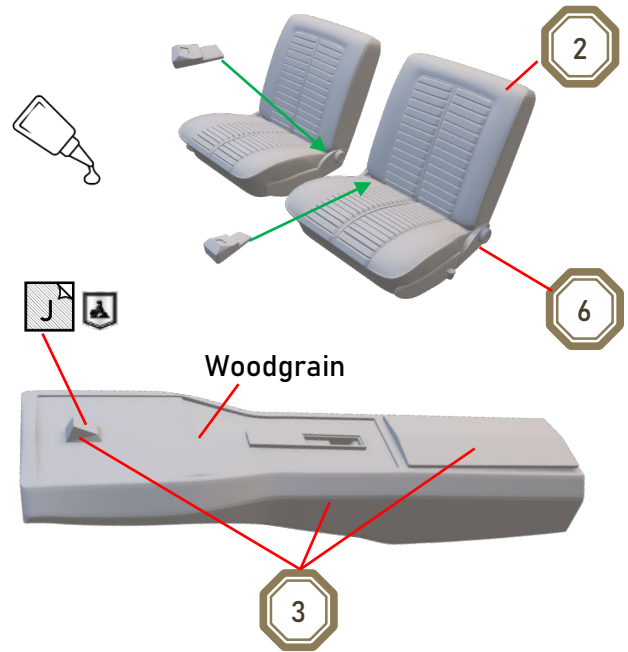

32.

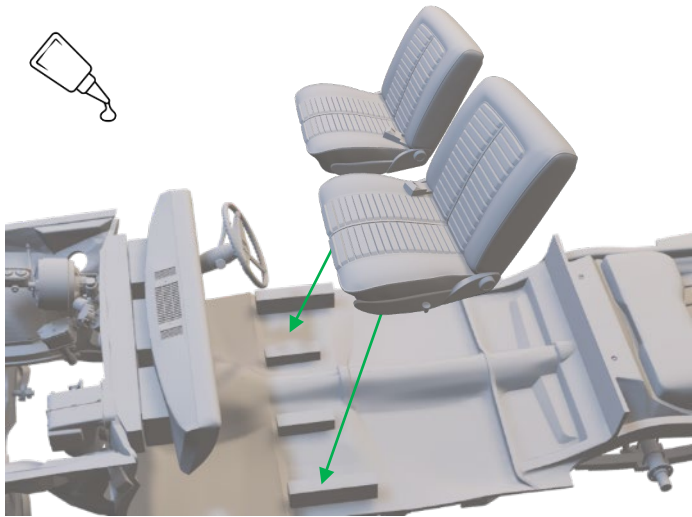

33.

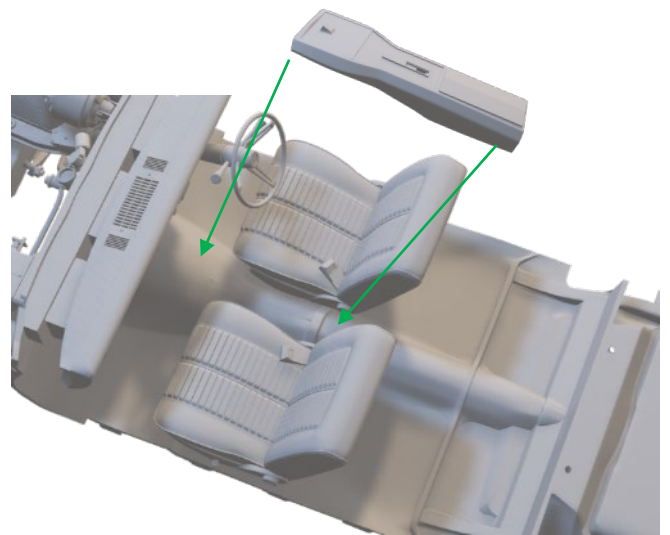

34.

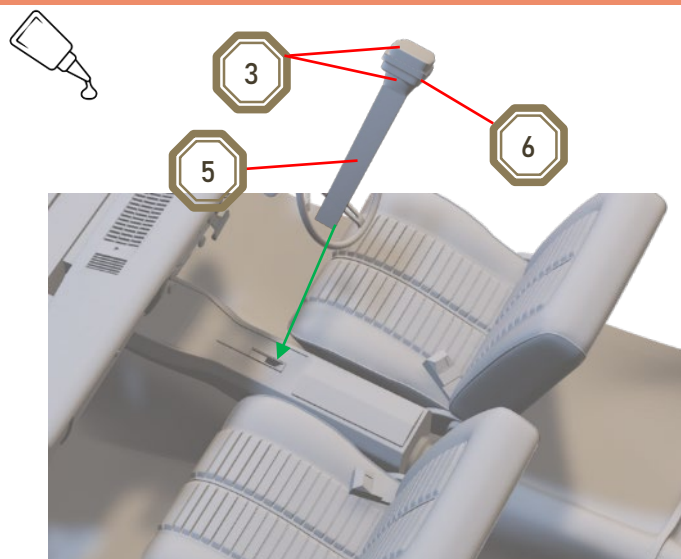

35.

Glue to gearbox crossmember (from Step 1) under, and engine mount points. Insert the drive shaft between the transmission and Diff.

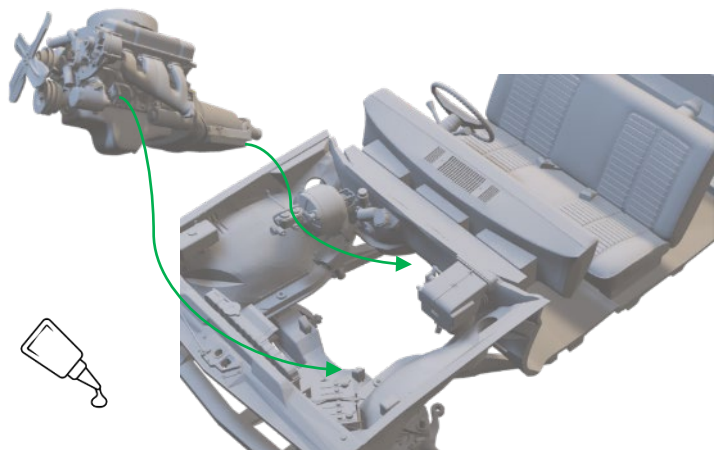

36.

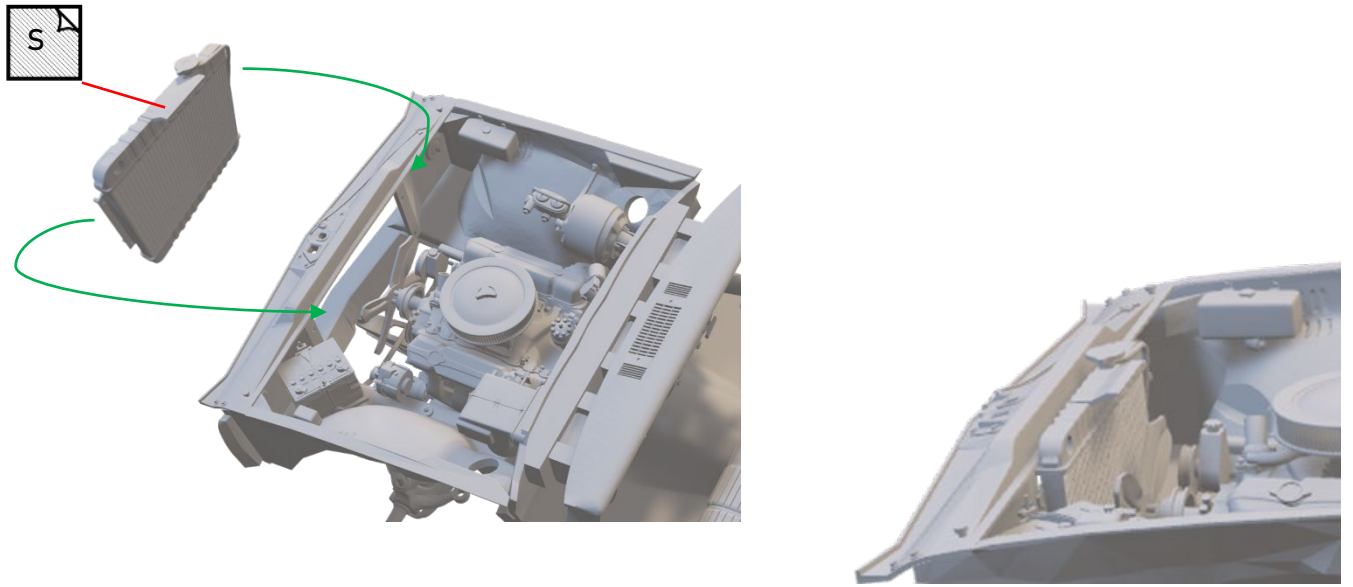

37.

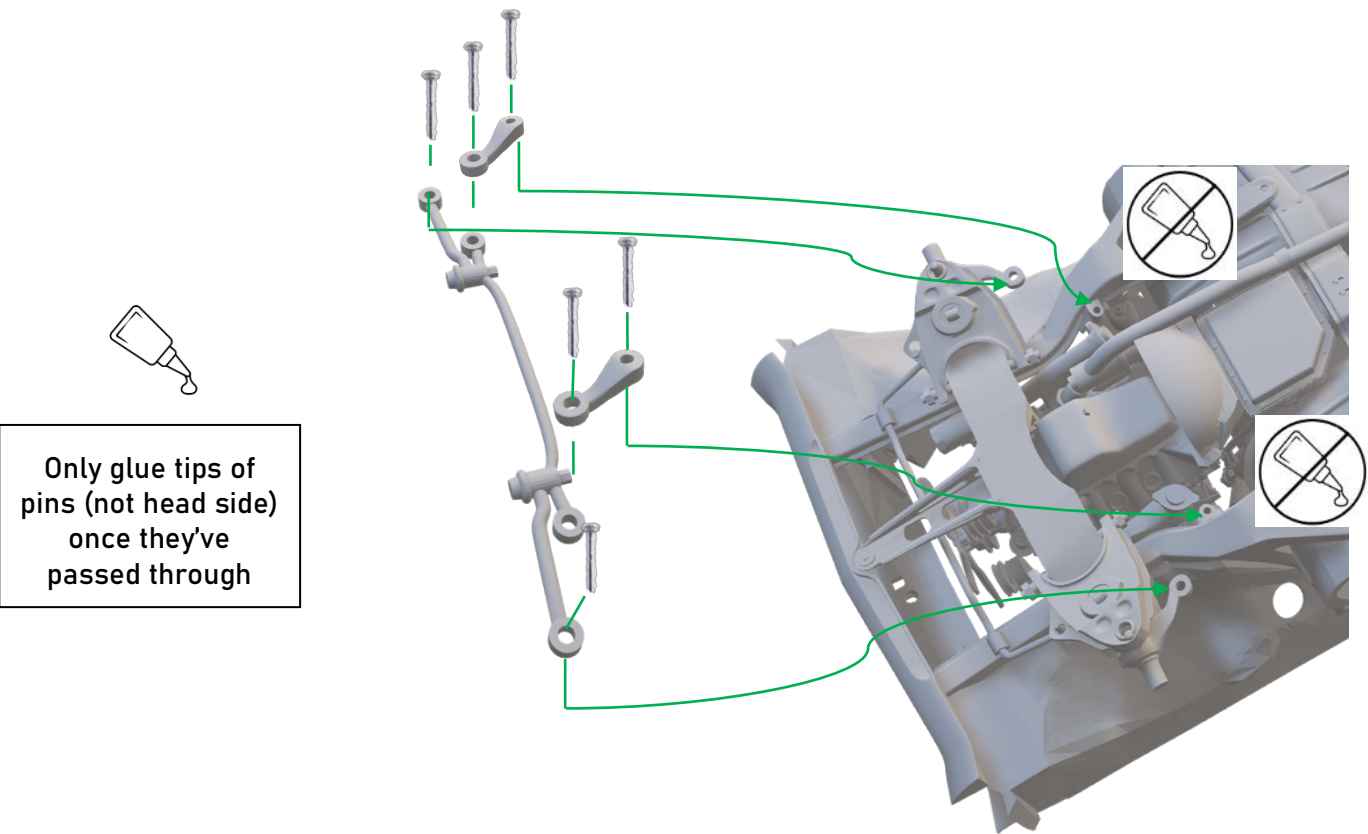

# 38. BODY

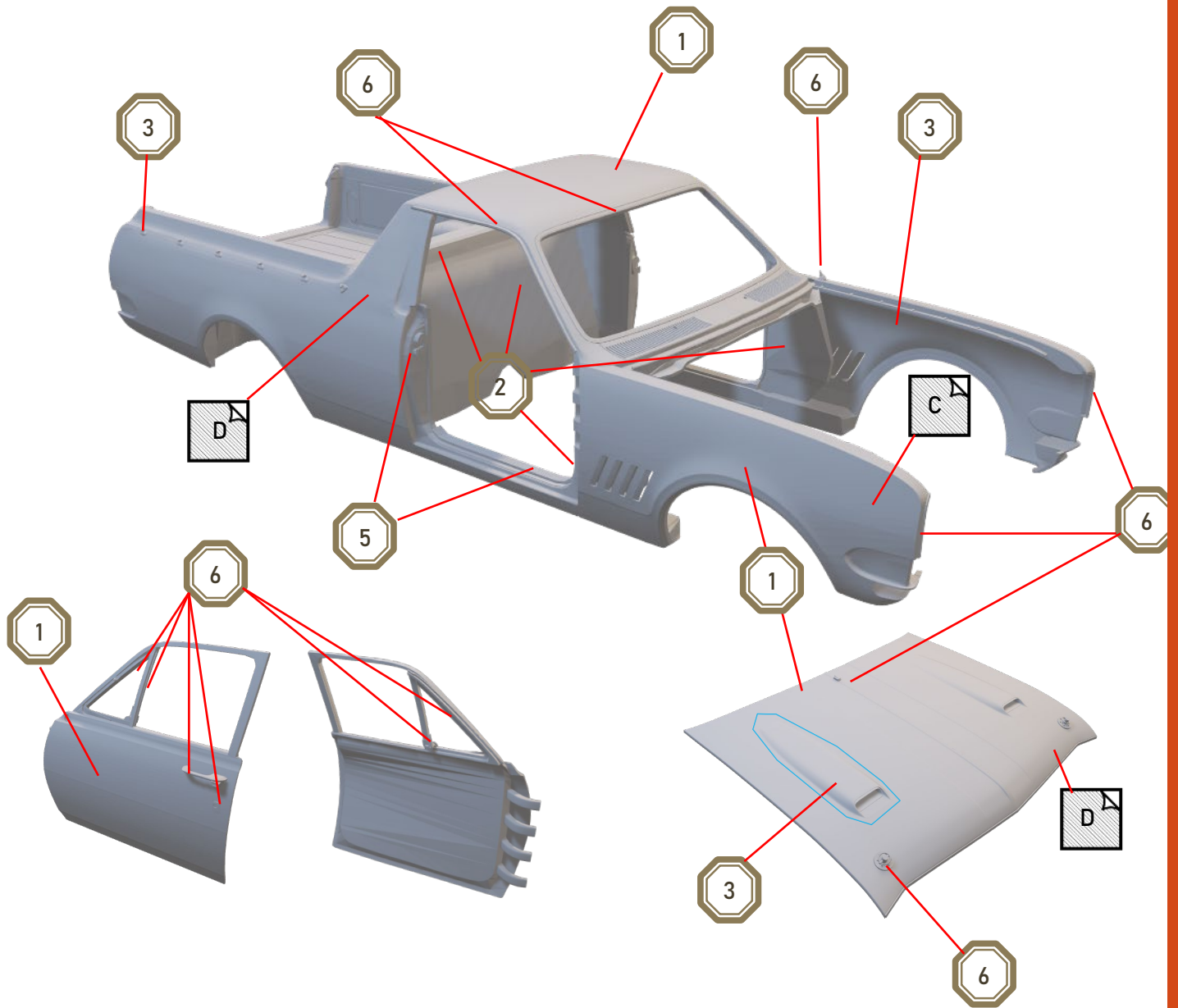

39.

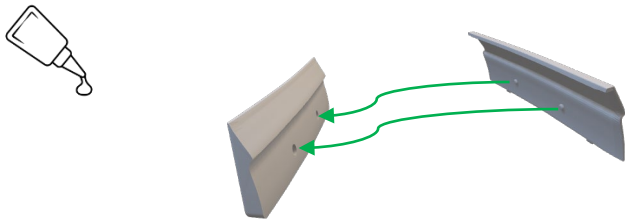

40.

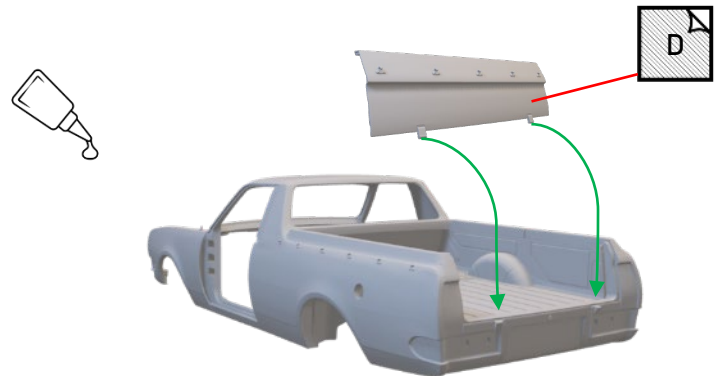

41.

42.

## 43. VAC FORMED WINDOWS

Apply interior paint to the interior of the vac formed windows.

Allow enough for the cut to be down behind the seat

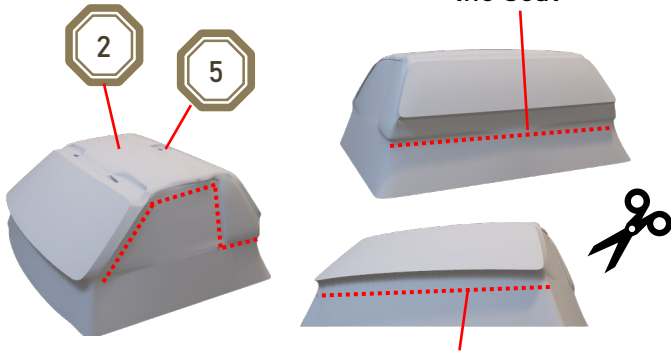

Not right up under windscreen, allow a few mm to slide down between body and dash

Use FOAM SAFE CA Glue (Supa-glue) for clear parts.  
Normal CA Glue will cloud the clear parts

## 44.

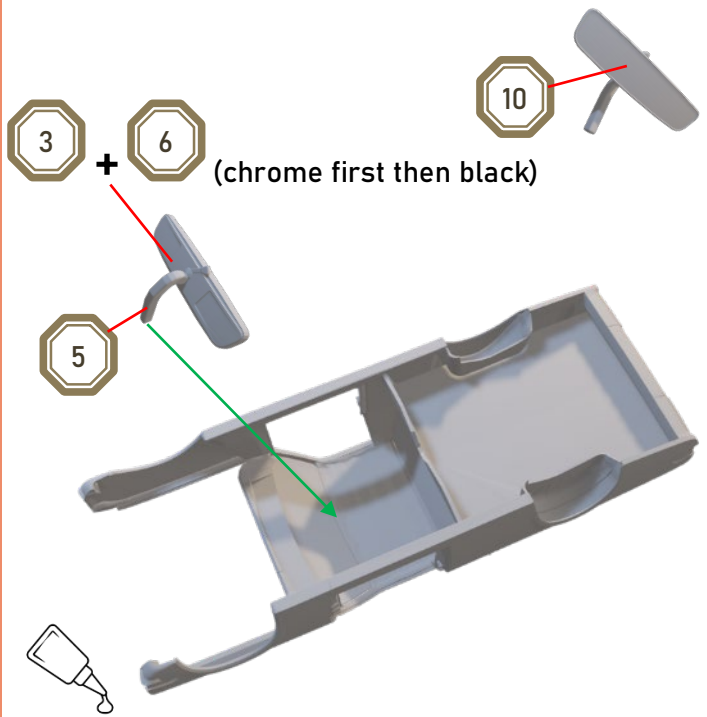

## 45.



yet

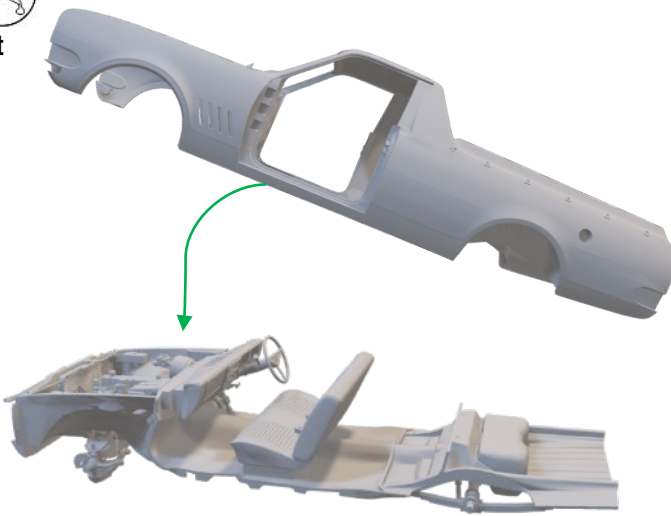

## 46.

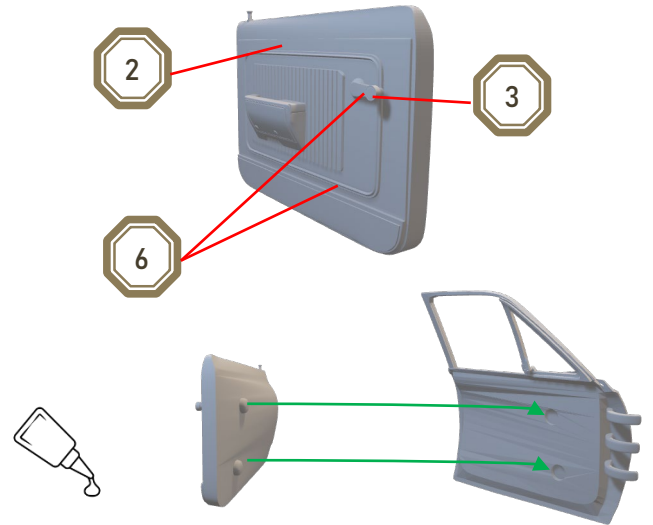



53.

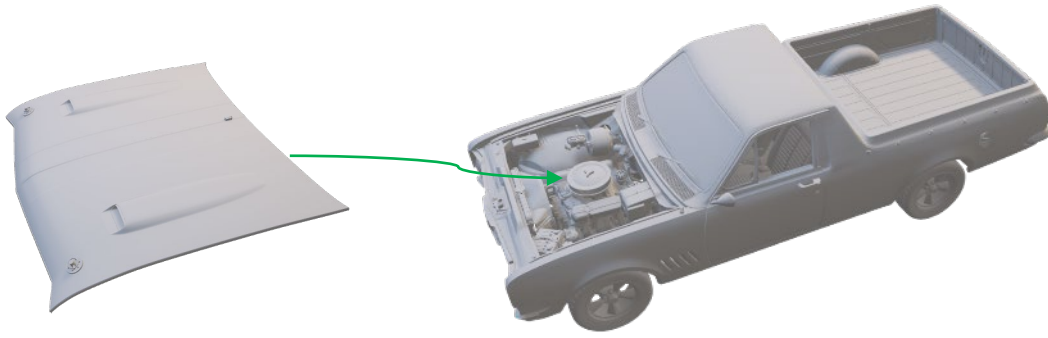

Congrat's. I sincerely hope you enjoy you model, and didn't lose too much hair in the process!

Thank you again for choosing a Fulbore Model Kit



[www.fulboremodels.com](http://www.fulboremodels.com)

**FulBore**  
Resin Models